

REV.	DESCRIPTION	BY	CHKD.	DATE
E	REVISED	J.S.S.		10/30/90
F	REVISED TO ADD LOCKING BAR	J.W.I.		12/02/91
G	REDRAWN ON NEW FORMAT WITH NEW PART#	S.S.	AMW	01/08/00
H	REVISED BOM PER CR #867	DD	AMW	05/29/02

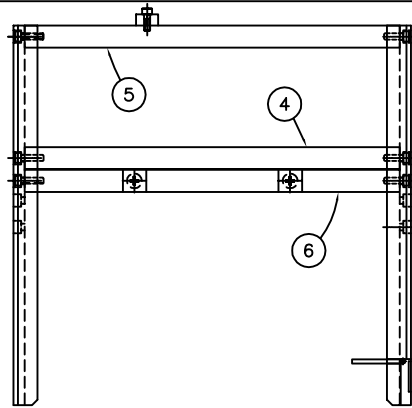

ITEM	ASM #	LEVEL 1 PART #	LEVEL 2 PART #	QTY	DESCRIPTION	FINISH
	5650-15					
		5650-15-P		1	MAGAZINE SUB ASSEMBLY	BLACK ANODIZE, TYPE II, CLASS 2
1			109940	1	MAGAZINE RH SIDE PLATE	BLACK ANODIZE, TYPE II, CLASS 2
2			109939	1	MAGAZINE LH SIDE PLATE	BLACK ANODIZE, TYPE II, CLASS 2
3			106230	1	BACKSTOP BAR (SHOWN ON 112707)	BLACK ANODIZE, TYPE II, CLASS 2
4			109942	1	TIE BAR (SHOWN ON 112507)	BLACK ANODIZE, TYPE II, CLASS 2
5			109943	2	TIE BAR (SHOWN ON 113854)	BLACK ANODIZE, TYPE II, CLASS 2
6			109941	1	TIE BAR (SHOWN ON 112508)	BLACK ANODIZE, TYPE II, CLASS 2
7			000-000461	10	SHCS - #6-32 X 1/2" LG, BLACK ALLOY	
8		000-000386		2	FHCS - #8-32 X 3/8" LG, BLACK ALLOY	
9		300-000471		1	LOCKING BAR (SHOWN ON 106366)	
10		000-000460		1	HANDLE	

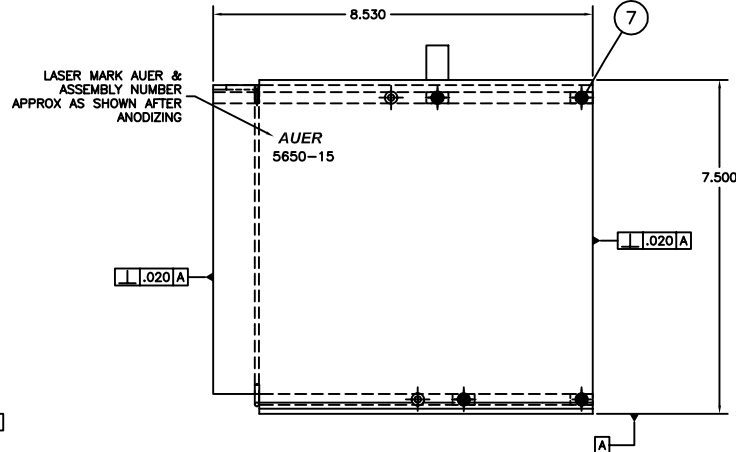
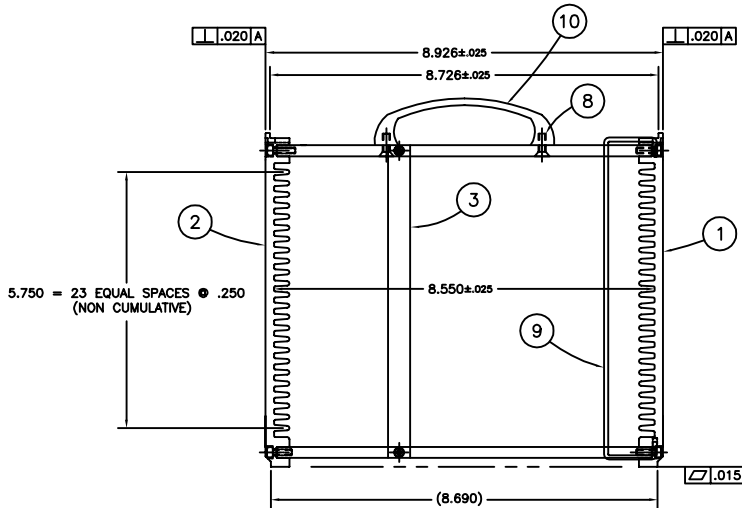

**CONTROLLED COPY**  
 IF THIS IS IN RED  
 AMW  
 Auer Precision  
 5/29/2002

NOTES: (UNLESS OTHERWISE SPECIFIED)  
 1. BREAK ALL SHARP EDGES .005R MIN.

**CONFIDENTIAL**

THIS DRAWING AND ALL INFORMATION HEREIN IS THE EXCLUSIVE AND CONFIDENTIAL PROPERTY OF AUER PRECISION COMPANY. THIS DRAWING IS FURNISHED IN AGREEMENT THAT IT OR ANY PART THEREOF WILL NOT BE REPRODUCED IN ANY MANNER OR DISCLOSED TO OTHERS WITHOUT THE EXPRESS WRITTEN CONSENT OF AUER PRECISION COMPANY. ALL PATENT RIGHTS RESERVED.

TOLERANCES (INCHES) UNLESS OTHERWISE SPECIFIED. X ±.02 JX ±.01 JXX ±.005 JXXX ±.0002 JXXXX ±.0001 JXXXXX ±.00005 ANG. TOL. ±2° DRAWING IN ACCORDANCE WITH ANSI Y14.5M.	DRAWN BY: PER DATE: 11/30/87	<b>AUER</b> PRECISION CO., INC. 1050 W. BIRCHWOOD MESA, ARIZONA 85210-8491 PH. (480) 834-4637 FAX (480) 964-8237	
	CHECKED BY: DATE:		TITLE: FILM FRAME MAGAZINE FOR AP16970-50 FILM FRAME
	ENGR. APPROVAL: DATE:		N.H.A.: REV:
	REF. PART NO. REV:		TOOL/DRAWING NO.: 5650-15 REV: H
	CUSTOMER/REF. NO.:		SIZE: B SCALE: NTS SHEET: 1 OF: 1
	PLOT DATE: 05/29/02		

